

G1478 STOCKPOT STOVE



KEY FEATURES

- Vitreous enamelled cast iron hob
 - Robust and hard wearing
- Removable cast iron pan support
 - Easy to remove and clean
- Powerful double ring concentric burner
 - Flexible control from fast boil to gentle simmer
- Heavy gauge tubular legs
 - Supports up to 40kg of weight
- Single control knob operation
 - Simple to use

MODELS and ACCESSORIES

G1478 stockpot stove

INSTALLATION NOTES

Adequate ventilation must be provided to supply sufficient fresh air for combustion and to allow easy removal of any such products that may present a risk to health. Please consult current legislation for details that relate to specific locations.

Install unit on a level, fireproof surface in a well-lit, draught free position. If floor is made of a combustible material, local fire requirements must be checked to ensure compliance.

A clearance of 150mm between appliance and any combustible wall and a minimum vertical clearance of 1220mm above top edge of flue should be observed from any wall or object liable to damage from overheating. Minimum vertical clearance of 550mm in still air above flue top edge is necessary to ensure overlying surfaces do not overheat.

Minimum clearance of 400mm from any adjacent wall at RH side is needed to allow removal of panel for servicing. LH side will become very hot. Position to minimise risk of accidental touching. Unit can be also mounted upon non-combustible bench legs, floor stand or wall brackets, never directly upon a table top.





G1478 STOCKPOT STOVE

MODEL DIMENSIONS (in mm)

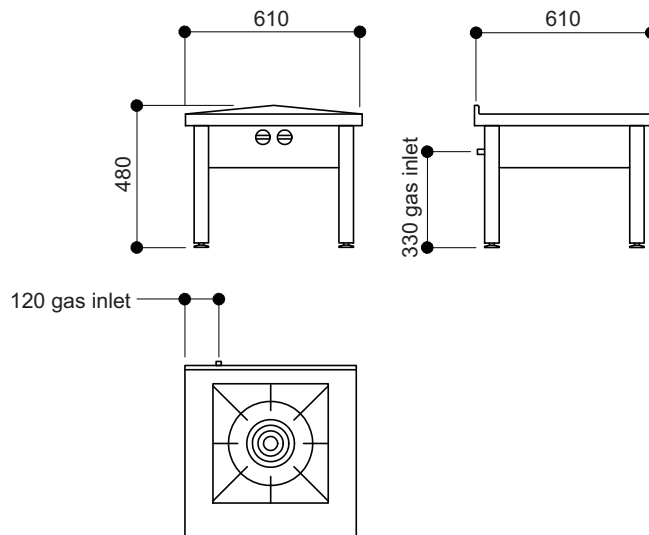

SPECIFICATION DETAILS

Total rating - Natural (kW - btu/hr)	14.6 / 49,820
Total rating - Propane (kW - btu/hr)	14.6 / 49,820
Inlet pressure (nat/prop. mbar)	20 / 37
Flow rate - Nat. (m ³ /hr)	1.55
Flow rate - Prop. (kg/hr)	1.14
Operating pressure (nat/prop. mbar)	15 / 37
Gas inlet (nat/prop.)	1/2" BSP
Weight (kg)	40
Packed weight (kg)	45